

PRINT[®]19

OCTOBER 3-5 | Thursday – Saturday

McCormick Place North | **CHICAGO**

PRINTevent.com



Tab 1

General Event Information

Event Services Deadlines Checklist

While this list highlights most major deadlines, please read through the entire manual to be aware of ALL deadlines.

JULY 11

- Early Rate Lead Retrieval Services — Tab 8

AUGUST 9

- Hanging Sign Notification and Diagrams due to APtech (only for exhibitors who may hang signs) — Tab 1

AUGUST 15

- Advance Rate Lead Retrieval Services — Tab 8

AUGUST 16

- Ad Closing Date Official Onsite Event Guide — Tab 7

AUGUST 27

- Exhibitor Badge Order Form — Tab 8

AUGUST 30

- Exhibitor Hotel Suite Request Form — Tab 9
- Hotel Reservations — Tab 9
- Request for Set-Up by Exhibitor Appointed Contractor (EAC) — Tab 3

SEPTEMBER 3

- Enviro-Guard (Hazardous & Non-Hazardous Waste Removal) Pre-Show Rate — Tab 2
- First Day for Shipments to Arrive at the Freeman Warehouse — Tab 4

SEPTEMBER 9

- Audio/Visual Discount Price — Tab 6
- Bottled Gases — Tab 4
- Bottled Water/Water Cooler Rental — Tab 6
- Carpet — Tab 4
- Catering/In Booth Dining Services — Tab 6
- Cleaning and Porter Services — Tab 4
- Display Labor — Tab 4
- Electrical Service — Tab 4
- Exhibitor Owned Carpet Installation — Tab 4
- Fabric Solutions — Tab 4
- Furnishings & Freeman Accessories — Tab 4
- Hanging Overhead Signs or Banners — Tab 4
- Material Handling Services and Rates — Tab 4
- Method of Payment, Freeman — Tab 4
- Paper Waste Removal — Tab 4
- Plumbing Service — Tab 4
- Rental Exhibits/Accessories & Custom Accessories — Tab 4
- Rigging Equipment & Labor — Tab 4
- Signs & Graphics — Tab 4
- Storage, Paper and Chemical — Tab 4
- Structural Integrity Statement — Tab 4
- TotalFlex Rental & Purchase Exhibit Units — Tab 4

SEPTEMBER 13

- Cable Television Service — Tab 5
- Computer/Technology Rental Discount Rate — Tab 6
- Floor Plan Template for Internet & Telecommunications — Tab 5
- Florist — Tab 6
- Internet Service — Tab 5
- McCormick Place Internet and Telecommunications Order & Payment Summary Form — Tab 5
- Telephone Service — Tab 5

SEPTEMBER 20

- Booth Security Guards Advance Order Rate — Tab 6
- Last Day for Shipments to Arrive at the Freeman Warehouse — Tab 4

SEPTEMBER 26

- Personnel, Temporaries — Tab 6
- Special Transportation Services — Tab 9

SEPTEMBER 28

- First Day for Targeted Shipments to Arrive at McCormick Place — Tabs 2 & 4
- First day to accept DHL, FedEx, and UPS deliveries — Tab 4

OCTOBER 2

- Advance Registration Deadline Attendee — Tab 8

OTHER FORMS

- Exhibit Floor Meeting Room Form (First come, first served) — Tab 1
- Photography & Video — Tab 6
- Security Cages/Containers — Tab 6
- 12 working days prior to target delivery date International Shipments to Arrive in U.S. by Ocean Freight (Less than Container Load) — Tab 4
- 10 working days prior to target delivery date International Shipments to Arrive in U.S. by Ocean Freight (Full Container Load) — Tab 4
- 7 working days prior to target delivery date International Shipments to Arrive in U.S. by Air Freight — Tab 4

Quick Reference Guide to Your Exhibitor Manual

Subject	Tab
Accessible Storage - Paper & Chemical	4
Advertising Opportunities	7
Air Shipments	4
APTech Staff and Key Contacts	1
ASUV	9
Audio/Visual	6
Bottled Gases	4
Business Center	6
Cable Television	5
Calendar of Events	7
Carpet, Brochure and Order Form	4
Catering	6
Charter Buses/Event Transportation	9
Cleaning and Porter Services	4
Complimentary Machinery Handling	4
Computer Rentals	6
Demonstrations on the Exhibit Floor	7
Display Labor	4
Display Rules	1
Directions to McCormick Place Marshalling Area	4
Electrical Service Information	4
Event Colors	1
Event Services Deadlines Checklist	1
Exhibit Floor Days and Hours	1
Exhibit Floor Meeting Room Form	1
Exhibitor Appointed Contractor (EAC) Request	3
Exhibitor Badges/Registration	8
Exhibitor Bill of Rights	3
Exhibitor Owned Carpet Installation Form and Shipping Labels	4
Exhibitor Tips & Frequently Asked Questions	1
Export Interest Form	7
Facility Information	5
Fire and Safety Regulations	5
Florist	6
Freeman Online Services	4
Freight, Ground/Air/International	4
Freight, Targeted	2
Frequently Asked Questions (FAQs)	1
Furniture, Brochure and Order Form	4
Glossary of Terms	1
Ground Shipments	4
Hanging Overhead Signs or Banners	1, 4
Hazardous Waste Removal/Disposal	2
Hotel Information/Suite Request	9
I & D Services, Freeman	4
Inbound (Move-In) Targeted Freight Schedule	2

Subject	Tab
Installation & Dismantling Schedule/ Building Specifications/General Information	2
International Shipments	4
Internet Services	5
Lead Retrieval Services	8
Marshalling Yard Map and Directions	4
Material Handling Services and Rates	4
McCormick Place Internet and Telecommunication Service Order & Payment Summary Form	5
McCormick Place Services and Regulations	5
Meeting Rooms on Exhibit Floor	2, 7
Move-In Targeted Freight Schedule	2
Official Promotional Listing	7
Official Contractors List	3
Parking	5, 9
Perfboard Panels, Bulletin Boards	4
Privately Owned Vehicles (POV) Routes	4
Personnel, Temporaries	6
Photography / Video	6
Plumbing Service	4
Press Briefings on Exhibit Floor/Press Briefing Room	7
Promotional Listing Form	7
Publicity and Promotion	7
Registration/Booth Personnel	8
Rental Exhibits Order Form	4
Rental Furniture, Brochure and Order Form	4
Rigging Information	4
Rules Governing Exhibition	1
Security	6
Shipping Instructions/Material Handling Information	4
Shipping Labels	4
Rules for Placement of Display	1
Sign Shipping Label	4
Signs	4
Social Media Tools	7
Special Handling Shipments	4
Storage – Paper and Chemical	4
Structural Integrity Statement	4
Targeted Freight Schedule	2
Telephone Service	5
Truck Traffic Routes/Marshalling Area	4
Union Jurisdictions at McCormick Place	4, 5
Video / Photography	6
VIP Guest Invites	7, 8
Waste Removal/Disposal	2
Water Coolers	6
Website Listing Information	7

Association for PRINT Technologies

Owner and Producer of PRINT[®]

Phone: (703) 264-7200

Email Domain: @apttech.org



Operations, Logistics, Contractors, Housing

Deedee Driscoll Tinkham, ext. 245 • dtinkham@

Booth Space, Exhibitor Support, Sponsorship Opportunities

Chrissie Hahn, ext. 267 • chahn@

Sondra Fry Benoudiz, ext. 222 • sfbenoudiz@

Kaitlyn Greene, ext. 270 • kgreene@

Accounts Payable

Beth O'Meara, ext. 272 • bomeara@

Crystal Young, ext. 275 • cyoung@

Kaitlyn Greene, ext. 270 • kgreene@

Meeting Rooms, Event Planning

Deedee Driscoll Tinkham, ext. 24 • dtinkham@

Kaitlyn Greene, ext. 270 • kgreene@

EACs and Insurance

Debbie Woodcock, ext. 286 • dwoodcock@

Registration

Kaitlyn Greene, ext. 270 • kgreene@

Crystal Young, ext. 275 • cyoung@

Marketing, Promotion, Media

Sarah Markfield, ext. 303 • smarkfield@

Jodie Haynes, ext. 246 • jhaynes@

RED HOT Technology Recognition, Seminars

Julie Shaffer, ext. 268 • jshaffer@



Event Days and Hours

Thursday, October 3	10:00 AM – 5:00 PM
<i>Celebrate PRINT!</i> Opening Reception	4:00 PM – 5:30 PM
Friday, October 4	9:00 AM – 5:00 PM
Saturday, October 5	9:00 AM – 3:00 PM

Celebrate PRINT! Opening Reception

Join us for an unforgettable evening of networking and celebration as the best and the brightest in the Printing Industry come together at the Celebrate PRINT! Opening Reception. The reception will be held throughout the Exhibit Floor, **Thursday, October 3 from 4:00 - 5:30 PM.**

Enjoy complimentary food and drinks alongside engaging conversations, networking and fun.

We look forward to seeing you there and continuing to provide the very best opportunities for you to connect, engage and promote at PRINT 19.



PLEASE NOTE: No one under the age of 14, infants included, will be admitted to the exhibit floor or seminars at any time. This applies to move-in, event days, and move-out. Childcare will not be provided. Everyone 14 years of age or older must register. There will be no exceptions. Proof of age may be required. Be sure to inform all company personnel of this policy.

I. Read this Exhibitor Manual in its entirety and the Exhibitor Insider (exhibitor resource updates) that is sent to you monthly. The information they contain will help you save time and money and will keep you organized.

II. Helpful Hints:

- A. Order your essential services in advance:
 - 1. Electrical labor and service
 - 2. Carpet and furniture
 - 3. Telephone/Internet
 - 4. Booth set-up and dismantling labor
 - 5. Booth security
- B. ON-SITE ORDERS ARE EXPENSIVE. Place your orders early and include payment to qualify for the discounts, and to ensure that your orders will be filled. Try not to place orders on-site.
- C. Confirm with Freeman and other contractors that your advance orders have been received before leaving for the show. Freeman will confirm all orders via e-mail or fax.
- D. Bring copies of your advance order forms to the show.
- E. Take a company credit card to pay all balances due on show site and for deposits on rental equipment.

III. Shipping Reminders:

Definitions

Crated: Material that is skidded or is in any type of shipping container that can be unloaded at the dock with no additional handling required.

Special Handling: Material delivered by the carrier in such a manner that it requires additional handling, such as ground unloading, side door unloading, constricted space loading, designated piece loading, and stacked shipments. UPS, FedEx, and DHL are included in this category due to their delivery procedures.

Uncrated: Material that is shipped loose or pad-wrapped, and/or unskidded machinery without proper lifting bars or hooks.

- A. Ship in advance to the warehouse or to the facility directly. Ship prepaid, and keep handy the inventory and the tracking numbers of all your shipments. Freeman will confirm receipt of warehouse shipments via e-mail or fax.
- B. Place a rider on your insurance policy covering the time your exhibit and product leaves your possession until it is returned. Your company is responsible for your exhibit and product.
- C. Ship your freight and product via common carrier or van lines to arrive on your target move-in date and time.
- D. Remove all old shipping labels before you send anything. Attach labels provided in Tab 4 of the Exhibitor Manual with your company name and booth number clearly marked.
- E. This schedule refers to the time your carrier has been assigned for check-in at the marshalling yard to be placed in line for unloading. Expect some waiting time for your trucks to be unloaded.
- F. When making your inbound shipping arrangements you can also plan your outbound shipping by filling out the Outbound Shipping Form provided on Freeman's website. Make sure someone from your company will be on-site to ensure all paperwork is filled out and turned in to the Freeman Service Center.
- G. Take the extra time to ensure that your display and product are packed neatly and securely.
- H. Shrink-wrap all your cartons onto a skid to avoid special handling charges.
- I. Ship early to avoid air freight charges.
- J. Alert Freeman if you are shipping out less paper than you shipped in.
- K. **Note that UPS, FedEx and DHL shipments will not be accepted at McCormick Place until Saturday, noon, September 28. Do not ship items using these carriers to your booth if needed for installation prior to September 28.**

IV. Common Shipping Mistakes:

- A. Selecting a carrier that does not service trade shows on a regular basis. Unlike other shipments, exhibit material is time-sensitive.
- B. Leaving old labels on crates and cartons that cause confusion.
- C. Not specifying what type of air freight service is desired (i.e., AM, PM, and second day and deferred service.)
- D. Not requesting insurance for valuable equipment and/or products.
If a shipment is not marked “insured,” it is covered for only a **\$100.00 maximum or 50 cents** for each pound per item.
- E. Not giving clear instructions on how the freight is to be shipped.
- F. Avoid common shipping mistakes and save yourself time, money, and needless aggravation by:
 - 1. Advising your carrier about your target date and time for move-in.
 - 2. Include an accurate description and pc count. Please state on BOL machinery, display or paper.
 - 3. Informing Freeman of the mode of transportation, whether it is common carrier, air freight, or van line.
 - 4. Reading the Exhibitor Manual and shipping instructions.
 - 5. Filling out the forms properly.
 - 6. Understanding the price per CWT 200 lb. minimum on shipments.

V. Gratuities are NOT permitted for move-in, set-up, move-out or any other service.

If you are pressured to give tips for service, please contact one of the show floor managers or Event Management immediately.

VI. Cost-saving ideas for booth installation:

- A. Consider renting a display from Freeman instead of designing, constructing, and shipping an original booth.
- B. Preassemble any parts on your equipment prior to entering the Marshalling Yard.
- C. Set-up your booth on straight time.
- D. Consider having Freeman supervise your booth set-up. Remember to include photos, set-up plans, and assembly instructions.
- E. Check in early at the Service Desk to confirm orders placed for labor, note all labor must be confirmed and signed for at the Freeman Service Desk.
- F. Be at your booth to supervise labor that has been ordered and reconfirmed at the service desk, as the clock starts from the time labor leaves the service desk or the previous booth.
- G. Try not to change or cancel your orders on-site.
- H. Review the rules in your Space Application and Contract, Rules Governing Exhibition and Display Rules in Tab 1 of your Exhibitor Manual.

VII. Frequently asked questions:

1. Q: What is included in my space rate?

A: APTech Event Management will furnish all in-line or linear booths with 8' high back drape and 36" high side dividers. Split island booths will be set with 8' high back drape along the back of the booths. Peninsula booths will be set with 8' high back drape along the center 6' of the booth, dropping to 36" high side dividers on each side. All booths, except islands, will be provided with a 7" x 44" identification sign with company name and booth number at no charge.

2a.Q: What are the show colors?

A: Different sections of the show floor will be color coded. Please visit the Freeman Quick Facts pages in Tab 4 of this manual for sections and colors.

2b.Q: Can I hang a different color back wall drape?

A: No. All back wall drapes must be the same color designated by the specific section of the show floor. This is to assist attendees in identifying sections of the show floor.

3. Q: How many exhibitor registrations do I get with my space?

A: Your company is entitled to 5 free badges per 10' x 10' booth for booths with less than 2000 sq. ft. Booths 2000 sq. ft. and greater receive 4 free badges per 10' x 10' booth. Additional badges over your allotment will cost \$49. **This is for company personnel only.**

4. Q: How early can I get on the exhibit floor during set-up and on event days?

A: Badged exhibitors will have access to the exhibit floor at 7:00 a.m. during set-up, event days and move-out.

5. Q: How late can I stay in the Hall to set up and dismantle my display?

A: Move-in is officially scheduled from 8:00 a.m. - 4:30 p.m. If you need to continue installation or dismantling work beyond 4:30 p.m., you **MUST** obtain a special pass from the Floor Managers' Desk by 3:30 p.m. that day.

6. Q: How do I label my freight?

A: Use the labels in Tab 4 of this Exhibitor Manual and make copies if you need more. Remove all old labels from your crates and cartons. To take advantage of complimentary machinery handling, please refer to Tab 4.

7. Q: What is a targeted date?

A: The targeted schedule is the assigned date/time for arrival of your machinery and freight. This schedule refers to the time your carrier has been assigned for checking-in at the marshalling yard to be placed in line for unloading. **THIS IS NOT WHEN THE FREIGHT WILL BE IN THE BOOTH.** Shipments sent direct to the convention center for arrival before your target date may be refused or asked to wait in line until all targeted shipments are unloaded. This may lead to overtime charges for your shipment.

8. Q: I can't meet my target date and time. What should I do?

A: Contact Freeman to request a new target date and time. Freeman will accommodate you if a new date and time can be arranged. Contact Lisa McGuinness at: freeman.chicago-targetchanges@freemanco.com or (773) 473-7436.

9. Q: What happens if I miss my target date or check-in time?

A: If you miss your target date or check-in time, your vehicle will not be unloaded until after all on-target vehicles have been unloaded, regardless of when your vehicle has checked in at the McCormick Place Marshalling Yard. This means you may incur a 25% additional charge for overtime unloading and cause your truck driver to wait all day for unloading.

Note: If your vehicle checks into the Marshalling Yard after 2:30 p.m., your driver may be turned away and asked to return the next day.

10. Q: How does my shipment get unloaded and will I be charged?

A: You must first check in at the Marshalling Yard. See Tab 4 in your Exhibitor Manual for directions. You will be charged based on the weight of your shipment. Shipments are charged a rate per CWT (100 lb.). There is a 200 lb. minimum. You may also be charged a special handling charge based on how your materials are shipped, i.e., crated or uncrated.

Crated: Material that is skidded or is in any type of shipping container that can be unloaded at the dock with no additional handling required.

Special Handling: Material delivered by the carrier in such a manner that it requires additional handling, such as ground unloading (trailer too low or too high to fit at the dock), side door unloading, constricted space loading, designated piece loading, stacked shipments (forklift cannot drive into the trailer and pick up the crate), loads mixed with pad-wrapped material, multiple shipments, carpet and/or pad only shipments, and shipments that require extra time, equipment, or labor to unload. **UPS, FedEx, and DHL are included in this category due to their delivery procedures.**

Uncrated: Material that is shipped loose or pad-wrapped, and/or unskidded machinery without proper lifting bars or hooks.

11. Q: May I unload my own vehicle?

A: If your vehicle is an automobile or small utility vehicle, you may unload your freight at the designated docks. Please note, this does not include company vans or trucks, rental trucks, or cars with trailers. Instructions and directions will be available closer to show and onsite. If you would like labor to unload the trucks or cars you drive, there will be a separate loading dock area for this service. Please note that the personnel unloading the vehicles must be employees of the exhibiting company. Please refer to the McCormick Place website or Tab 9 of this manual for ASUV information for self-unloading.

Exhibitor Tips and Frequently Asked Questions

12.Q: How early can I ship to the Freeman warehouse?

A: The first day for shipments to arrive is September 3, 2019; the last day shipments will be accepted is September 20. Machinery must be shipped to show site.

13.Q: Can I ship direct to the convention center?

A: Yes. However, if your shipment arrives prior to your target date for move-in, the shipment may be refused. **No UPS, FedEx, or DHL shipments will be accepted until Saturday, September 28, 2019.**

14.Q: Will tipping get my truck unloaded sooner?

A: No. Labor has been instructed to unload any exhibitor LAST who has offered a gratuity. Also, please alert your Floor Manager of any attempt to solicit gratuities.

15. Q: Where does my shipper need to go to check in?

A: All trucks need to enter the McCormick Place Marshalling Yard and check in. Also, please see the targeted schedule for check-in under Tab 2. The trucks are assigned a number and wait in the Marshalling Yard for their number to be called. McCormick Place requires payment of a fee of \$23.00 for all trucks to enter the McCormick Place Marshalling Yard. This fee is subject to change. Payment of this fee allows entry for 24 hours or less with in and out privilege for the Marshalling Yard only. This fee must be paid by the driver at the entrance to the Marshalling Yard, which is staffed by McCormick Place security personnel. The fee can be paid in cash or with a major credit card. Checks or debit cards cannot be accepted and this fee cannot be paid in advance. Please be sure to alert your non-courier freight transportation provider. The Marshalling Yard has a truck scale, if needed. Call (312) 808-3161 with any questions or for directions.

16.Q: Do I have to wait for a crew to unload or load my freight?

A: Yes, if you are unloading at the docks. You can hand carry as much freight through the show entrance as one person can carry in one load. You may use a manual handcart or dolly. This includes small computers and pop-up displays. If you are driving your own small utility vehicle or automobile, you may unload your own freight at the times specified. Please refer to the McCormick Place website for information on self-unloading.

17.Q: How do I file a claim for missing or damaged inbound freight?

A: Go to the Freeman Service Desk on-site.

18.Q: If I keep my empties until the last minute, will I get them back first?

A: No. If you hold your empties, the Floor Manager will warn you first and then have your empties removed. This is a requirement of the Fire Marshal.

19.Q: When will I get my empty crates back?

A: It will take approximately 1 hour to roll up all the carpet, then cartons will begin to be returned so you can start packing, and then crates will be next. Crate return is random.

20.Q: How much paper can I store within my booth?

A: Fire Marshal rules permit you to store only one day's supply of paper.

21.Q: Can I store my empties behind my booth?

A: No. The Fire Marshal requires all empties, cartons and crates to be removed from behind the booths. Empty stickers are to be placed on these items for pickup by Freeman.

22.Q: How are material handling charges based?

A: Material handling rates are based upon incoming weights. Make sure your carrier provides Freeman with a Heavy and Light weight scale ticket as well as making sure the BOL clearly states Machinery, Display & Paper.

23.Q: What is the Complimentary Machinery Handling Program?

A: Unlimited **complimentary** machinery handling with purchase of booth. See Tab 4 for more information.

24.Q: What is included in the Machinery Handling Program?

A: Unloading machinery from inbound carriers; show site delivery of machinery to the exhibitor's booth space, including one-time spotting (exhibitor must be present); storing empties, return of empties, and loading of machinery onto outbound carriers at close of the show. Please contact Chrissie Hahn with questions at: chahn@aptech.org or (703) 264-7200.

25.Q: What constitutes machinery?

A: All machinery to be displayed in an exhibitor’s booth space, regardless of total weight, not including paper, display materials, computer demos and floor coverings.

26.Q: What is included in the spotting charge?

A: Spotting of machinery is included providing the exhibitor is present during unloading and nothing will need to be uncrated, unskidded, unbolted or assembled. Follow the instructions under “Machinery” in the Freeman Quick Facts under Tab 4.

27.Q: What is not included in the one-time spotting charge?

A: One-time spotting does not include any unbolting, unskidding or assembly.

28.Q: Who removes heavy skids and machinery crates?

A: Your installation rigger crew removes heavy skids and machinery crates requiring a forklift truck from the booth at hourly rates and places them in storage.

29.Q: How do I get back my heavy skids and machinery crates from storage?

A: Your dismantling rigger crew is responsible for returning your heavy skids and machinery crates from storage.

30.Q: How do I order heavy skid and machinery crate removal and return?

A: Refer to the “Rigging and Machinist Information” page in Tab 4 for details and use the “Freeman Rigging Labor” form. This form is also used to order machinist labor that will set your machinery.

31.Q: What additional charges could I incur under the Machinery Handling Program?

A: Potential charges not included in Complimentary Machinery Handling Program:

1. If machinery is unloaded or loaded out on Saturday or Sunday, the exhibiting company will incur an additional charge for overtime based upon weight of shipment.
2. If you miss your target date or check-in time, your vehicle will not be unloaded until after all on-target vehicles have been unloaded, regardless of when your vehicles checked in at the McCormick Place Marshalling Yard. As a result, you may incur an additional charge for overtime unloading and cause your truck driver to wait for unloading. If your vehicle checks into the Marshalling Yard after 2:30 p.m., your driver may be turned away and asked to return the next day. **A fee of \$2.30 per cwt. will be charged for machinery shipments unloaded off target on straight time.**
3. Labor time and equipment fees will be charged if:
 - a.) machines arrive in containers
 - b.) blocking, re-blocking, un-stuffing, removing tarp or re-tarping is involved
 - c.) it is necessary to un-skid machines before removing from container
 - d.) sides and/or top of truck have to be removed by contractor
 - e.) machines are crated or skids require removal
 - f.) additional spotting of machines after unloading or handling of empty skids
 - g.) machinery crates to and from storage area are required
4. If an exhibitor representative is not present during unloading and delivery time, machines will be placed in the booth without spotting. For spotting later, fees based on labor time and equipment will be charged.

32.Q: Can I bring my own carpet?

A: Yes. Provided you do not use a powered vehicle to transfer it on the show floor.

Note: All carpet and drape **MUST** be made of a fire-retardant material. Also, please ensure that all carpet padding, and tape is removed from show floor during move-out.

33.Q: Is carpet required?

A: No, you are not required to carpet your booth space.

34.Q: What charges will I incur if I wish to use my own furniture or carpeting or rent these items from a non-official provider?

A: You will incur material handling charges for the unloading, delivery, and loading out of these items. If these items arrive loose and uncrated, you will be charged at the special handling rate. If they arrive or are loaded out on overtime, or off target, you will be invoiced accordingly. If the carpeting requires labor to put down, tape and pick up, you may incur labor charges. If you rent furniture or carpeting from the official contractor, there will be no additional material handling charges and your carpet will be put down prior to your assigned target date.

35.Q: Can I hang my own signs in my booth?

A: Yes. Power tools and ladders are permitted, but must be supplied by exhibitor.

36.Q: Can I use my own skirt or drape on my table?

A: Yes.

37.Q: Can I erect and tear down my own display?

A: Yes. Exhibitor staff may erect and tear down their own display.

38. UNION LABOR JURISDICTIONS

Q: McCormick Place is a union building. What does being a union building mean?

A: In a union building, jurisdictions are clearly established for the various work trades, i.e., riggers, teamsters, display labor, cleaning/porter service. Refer to “Union Jurisdictions at McCormick Place” under Tab 4.

Q: Will I be required to use union labor to set up my booth?

A: No. Exhibitor staff may erect and tear down booths.

39.Q: Can I carry in my computer?

A: Yes. You can hand-carry in small computers and appliances. You may use a manual handcart or dolly. No mechanized or hydraulic lifts, carts, or scooters allowed.

40.Q: Can I carry in my pop-up booth?

A: Yes. You may carry in small packages, including pop-up booths. You may use a manual handcart or dolly. Mechanized or hydraulic lifts, carts, or scooters are not allowed.

41.Q: Can I assemble my own machines?

A: Yes. You are permitted to do the technical assembly. However, riggers are responsible for unloading, uncrating, unskidding, spotting, non-technical assembling and reskidding all machinery.

42.Q: How far does my machine have to be set back from the aisle?

A: Static machinery can be placed in any location of the booth and is restricted only by building ceiling height and floor load. For safety reasons, machines and equipment operating or demonstrated at any time during show hours **MUST** be placed so that no portion is closer than 12 inches to aisles. Machines must be set within the booth space to allow for printed output to fall within the booth space and not in the aisle.

43.Q: Can I cover the columns in the exhibit hall?

A: Yes, but strobe lights (fire enunciators) on all columns **MUST be clear and visible**. Also, you may only cover column sides that are inside your booth space.

Note: Fire Hose Cabinets (FHC) and electrical cabinets **MUST** be easily accessible at all times. Please contact Chrissie Hahn at: chahn@aptech.org or (703) 264-7200 with any questions.

44.Q: How high can I hang my sign?

A: Hanging signs for island and split island booths will be permitted to a maximum height of 24 ft., including a mandatory 3-ft. space for visibility purposes between the top of the booth display to the bottom of the hanging sign. Height limitations for other booth configurations are as follows:

Peninsula booths: 16 ft.

Linear booths 20 ft. deep or greater: 16 ft.

Perimeter booths: 12 ft.

Standard linear booths under 20 ft. deep: No hanging signs permitted.

45.Q: How do I track my shipment?

A: If you have not received your return shipment in 7 to 10 days, call Freeman at: (773) 473-5040 and ask for the “Tracking Department.”

46.Q: What is the difference between Extended Power and 24-hour Power?

A: 24-hour power orders are for show days only. Extended Power is for additional power needed outside any of the scheduled install/dismantle days/times. To reference these days/times, please refer to Tab 2.

47.Q: When does 24-hour power begin?

A: When ordered, 24-hour power begins 30 minutes prior to show opening and is turned off 30 minutes after final show closing.

48.Q: I require labor past 4:30 p.m., what do I do?

A: If you need to work past 4:30 p.m. during set-up, you must notify Freeman no later than 1:30 p.m. that same day. If you need to schedule manpower prior to 8:00 a.m. for the following day, you must notify Freeman by 1:30 p.m. the day before.

49.Q: Is Wi-Fi available at McCormick Place?

A: Yes. Complimentary Wi-Fi for personal devices is available in the public spaces of the convention center, including all common hallways, meeting rooms, and in the exhibit hall. See Tab 5 for more information and to order wired internet service for your booth.

50.Q: Where can I park at McCormick Place?

A: Tab 9 in your Exhibitor Manual has information on “Exhibitor Guaranteed Parking” and general parking.

51.Q: Can I bring in my own food and beverages to McCormick Place?

A: You may bring in an item for you or your staff to consume like sodas or lunch, but any food or beverage you wish to serve to others must be provided by SAVOR...Chicago, the exclusive catering provider at McCormick Place. Please see Tab 6 for menus, pricing and policies.

52.Q: Still not sure what to do. Who do I call?

A: See page 4 for specific questions and staff to contact.

EXHIBIT DISPLAY RULES

PRINT 19

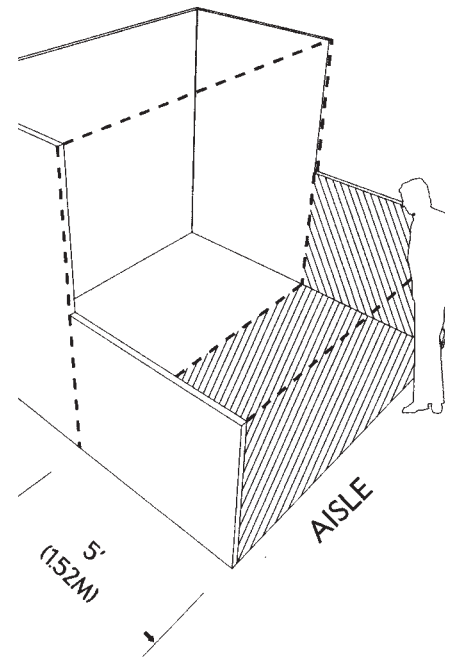

EXHIBIT DISPLAY RULES

Your type of booth (island, linear, etc.) can be found in your confirmation letter.

GENERAL (Applies to all booth configurations)

The purpose for display rules, hanging sign regulations and height restrictions is to provide equal visibility to all exhibitors. At the same time, these guidelines should maintain the inherent benefits of differing booth configurations. The Association for PRINT Technologies (APTech) enforces these rules in all of their events in an effort to maintain consistency, and to prevent any one company from gaining an unfair advantage over another in attracting the attendees' attention during the event.

DISPLAY

Your type of booth (island, linear, etc.) can be found in your confirmation letter.

Display materials consist of floor structure, pre-fabricated columns, panels, back drops, table top displays, counters, booths, non-hanging signs, pedestals with product on top, pop-ups, etc. Display height is allowed at 8 ft., 12 ft. or 16 ft., depending on the booth configuration. See pages that follow for display height rules for each type of booth space.

Please note that these regulations apply to display only; machinery regulations are noted under "Placement of Machinery."

HANGING SIGNS

Hanging signs are part of the overall exhibit presentation and, therefore, must be treated as a component of the total exhibit configuration. All signs, whether suspended or attached to the exhibit fixture, will be permitted to a maximum height that corresponds to the appropriate area on the exhibit floor as well as exhibit configuration as noted below.

Exhibits should follow these rules for hanging signs:

Height: Hanging signs for island and split island booths will be permitted to a maximum height of 24ft. (top of sign) including a mandatory 3 ft. space for visibility purposes between the top of the display to the bottom of the hanging sign. Height limitations for other booth configurations are:

- Peninsula booths: 16 ft. (top of sign stays within 16 ft. display space, no 3 ft. space required)
- Linear booths 20 ft. deep or greater: 16 ft. (top of sign stays within 16 ft. display space, no 3 ft. space required.)
- Perimeter booths (linear): 12 ft. (top of sign stays within 12 ft. display space, no 3 ft. space required.)
- Standard linear booths under 20 ft. deep: **no hanging signs permitted.**

Depth and Position in Booth: All signs must remain inside the outline of the space sold. Island booths may hang signs anywhere inside their booth space. Split island booths, peninsula booths, and linear booths 20 ft. deep or greater must set hanging signs forward from the back line of the booth (the back or side of booth shared with another exhibitor) at least 25% of the booth's width dimension so as not to detract from the overall impact of the exhibits that are directly adjacent. Perimeter booths (linear) may only hang signs in the back 5 ft. of their booth - signs must be set back 5 ft. just as display items would be.

All PRINT 19 hanging sign designs must be sent to Event Management for approval by **August 9** and exhibitors must have drawings available for inspection by Event Management,

the installation and dismantling contractor, and the facility during the event.

Sign placement may be restricted because of low ceiling heights and limited hanging points in the convention center. Please send hanging sign designs along with booth design and layouts to: chahn@aptech.org.

COMMON WALL

Surfaces common to adjoining booths may not contain any signage, graphics, etc., and must be finished in a neutral color. This includes display, signs, banners, or towers placed against a common wall.

HEIGHT RESTRICTION FOR OVERHEAD LIGHTING/TRUSS

For island, split island, or peninsula booths, hanging lights used for display lighting and truss used for lighting or attaching signs may be hung at any height without prior approval from APTech. This also applies to special fabric used specifically to block light (scrim) only if it is used horizontally. Lighting housing, truss, and fabric/scrim may not contain graphics or promotion, and may not have graphics projected upon them if higher than the hanging sign limit. Vertical fabric/scrim, even without graphics, is considered either a hanging sign when hung from the ceiling or booth display if set on the ground and must follow the relevant hanging signs or booth display rules.

HEIGHT GUIDELINES FOR AIR MOISTENING/MISTING EQUIPMENT

Exhibitors displaying equipment that emits water particles into the air must follow these rules to ensure that their displays and moisture output do not interfere with other exhibitors' displays.

- The output from all units must be no lower than 10 ft. from the ground so that the output from the nozzles has adequate space to disperse before reaching other booths. For linear booths, this means that equipment may only go as high as 16 ft. and the top of the equipment where the mist comes out can be no lower than 10 ft. from the ground. These heights are only applicable to equipment; display elements must still remain 8 ft. or lower for linear booths.
- All exhibitors must follow the set-back rule for running machinery: please see below for Placement of Machinery Rule (12 inches from the edge of the booth). In addition, companies with air moistening or misting equipment must ensure that the output is at least 2 ft. away from neighboring booths on the sides or the back and that all moisture emission is facing away from neighboring booths. In other words, all water droplet output must occur inside the confines of the exhibitor's booth, not in the aisles or in neighboring booths, and jets or nozzles may not be directed toward neighboring booths. Event Management reserves the right to move any exhibitor that does not comply with these rules.
- Please note that any complaints from neighboring booths will be evaluated by Event Management and options will be discussed with each individual exhibitor if a situation arises. If possible, please run your equipment for demonstrations only and plan to adjust the volume of output if necessary.

PLACEMENT OF MACHINERY

Static machinery of any height can be placed in any location of the booth and is restricted only by building ceiling height and floor load. For safety reasons, machines or equipment operating or demonstrated at any time during exhibit hours shall be placed so that no portion is closer than 12 inches to aisles. Machines must be set within the booth so that any printed matter will fall within the booth space and not in the aisle.

TOXIC VAPORS & GASES

Exhibits and equipment that emit vapors and gases that are flammable, toxic, or generally unpleasant for the public may not be used inside the halls. All other vapors and gases must be directed into the open air through non-combustible piping or venting, or an appropriate filter (i.e. charcoal) must be fitted to bring ozone exhaust to acceptable levels as determined by Event Management for the safety of attendees and exhibitors.

COLUMNS

Exhibitors in Island or Split Island booths may decorate a column that is located within their booth space. Only sides of a column that fall within an exhibitor's booth space may be covered or decorated. No columns or side of columns in aisles may be covered by exhibitors. Columns may be decorated to a maximum height of 15'6", with openings for strobe lights and signs. If columns have utility boxes or fire safety equipment behind storage doors, these doors must be visible and accessible at all times so fire safety personnel can easily access the fire hose and remove it in the event of fire. No walls or machinery are allowed in front of the cabinet doors at a distance that would prevent someone from accessing the equipment in the fire hose cabinet. Also, please note there are strobes on all four sides of each column that may not be covered. Please contact Event Management for further details regarding columns in your booth space.

INSTALLATION AND DISMANTLING

Hours and dates for installation, showing and dismantling shall be those specified by Event Management. It is the duty and responsibility of each exhibitor to have their exhibit completely installed in assigned booth area before the opening of the exposition and to dismantle and remove their exhibit after the close of the exhibition. **Exhibitors are not permitted to dismantle their booths prior to the published end of show hours.** If an exhibitor dismantles their booth prior to the published end of show hours, the exhibitor may be subject to a penalty by deducting priority points. Exhibitors shall be liable for all storage and handling charges resulting from failure to remove exhibit material from the exposition before conclusion of the dismantling period as specified by Event Management.

PRESENTATIONS

Presentations and sampling must be organized within the booth so that crowds which gather are contained within the limits of the booth and do not interfere with any traffic aisle. All literature distribution or marketing efforts must be conducted inside the booth space. Marketing in the aisles or any place other than the booth is prohibited without prior approval by Event Management.

SOUND/MUSIC

Event Management reserves the right to restrict exhibits which, because of noise, method of operation, or any other reason, become objectionable, or otherwise detract from or are out of keeping with the character of the exhibition as a whole. Exhibitors may use sound equipment in their booths so long as the noise level does not disrupt the activities of neighboring exhibitors. Speakers and other sound devices should be positioned so as to direct sound into the exhibitor's own booth rather than the aisle.

MEETINGS IN BOOTH

Exhibit floor news briefings, special demonstrations, and functions will be permitted on all event days. If you plan to hold a function before event hours on the exhibit floor, you may do so beginning at 8:00 am on Friday, October 4 and Saturday, October 5. If you would like to hold a function on the exhibit floor after the event closes you may do so only on Thursday, October 3 and Friday, October 4. The event must be concluded by 6:00 pm.

All guests must be registered and have their badges and the person or group must present a Special Admissions Pass completed by Event Management to enter the hall. The Special Admissions Pass is available in the Event Office and should be requested at least one day prior to the event. For morning events, the group should gather outside the hall, enter together, and remain together during the hour prior to exhibition opening. For evening events, the group should remain in the host's booth and leave directly from the booth to the exit by 6:00 pm.

HOSPITALITY ACTIVITIES

Exhibitors hosting hospitality functions off the exhibit floor must refrain from holding these activities during official exhibition hours with the exception of luncheon events. Exhibitors may not transport attendees to off-site events during exhibition hours. Only exhibitors in good standing are permitted to host or sponsor a hospitality function in an official event hotel. All requests for hospitality suite or public function space must be approved by Event Management.

FOOD & BEVERAGE DISTRIBUTION

No popcorn, peanuts with shells, or other items determined to cause debris in aisles and neighboring booths may be served at any time from an exhibitor's booth.

BOOTH APPEARANCE AND THE RIGHTS OF OTHERS

Event Management may require any exhibitor to make changes in an exhibit if, in Event Management's opinion, the exhibit does not conform with prevailing standards of good taste. Changes will also be required if the exhibit interferes with the rights of others. Event Management may also require that an exhibit be professionally finished at the expense of the exhibitor if the exhibit has not been finished or is in any way deemed unsightly. An example of this would be requiring that the side corner of a booth be draped if the back of a pop-up display is visible from the aisle. Exhibitors must arrange to remove excessive amounts of trash or waste materials during exhibit hours.

RESPONSIBILITY OF PROPERTY

Event Management will provide perimeter guard service during the hours the exhibit area is closed; however, exhibitors are solely and fully responsible for their own exhibit material and should insure their exhibit against loss or damage from any cause whatsoever. All property is

understood to remain in their care, custody, and control in transit to or from or within the confines of the exhibit hall. Exhibitors are encouraged to hire booth security guards or use the security storage that is provided and should insure their property at their own cost and expense.

BOOTH DESCRIPTIONS

DISPLAY SET-BACK FOR LINEAR BOOTHS

(A linear or “in-line” booth has traffic on 1 or 2 sides, faces a numbered aisle, and is 10 feet deep—exception for 20 foot linear booths below.)

Linear booths less than 30 feet long must maintain an area 5 feet from the aisle where display items cannot be higher than 4 feet. The maximum height for display materials in the rear 5 feet of the booth is 8 feet.

Linear booths 30 feet long or longer must abide by the above linear display rules, but may use the middle 1/3 section of the booth out to the aisle with no 5 foot set-back (neighboring exhibitors must be at least 10 feet away from the middle section that goes 5 feet high.)

MAXIMUM DISPLAY HEIGHT: 8 FEET

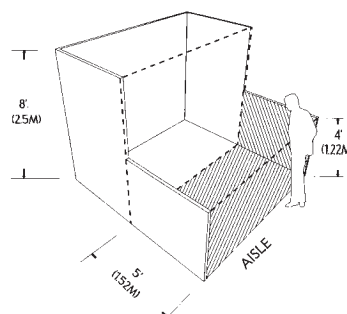

Linear Booths

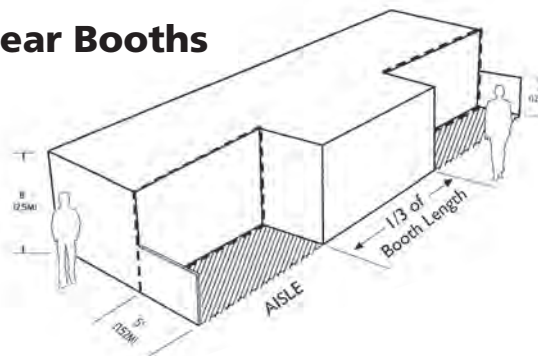

Special note for linear booths at least 20' deep and 599 total square feet or less: (A linear booth has traffic on 1 or 2 sides, and faces a numbered aisle.)

The exhibitor must maintain an area 2 feet deep by 5 feet along the numbered aisle adjoining a neighboring booth where display material can be no higher than 4 feet. The maximum height for display materials in the rest of the booth is 16 feet.

MAXIMUM DISPLAY HEIGHT: 16 FEET
(Except 4 feet where noted.)

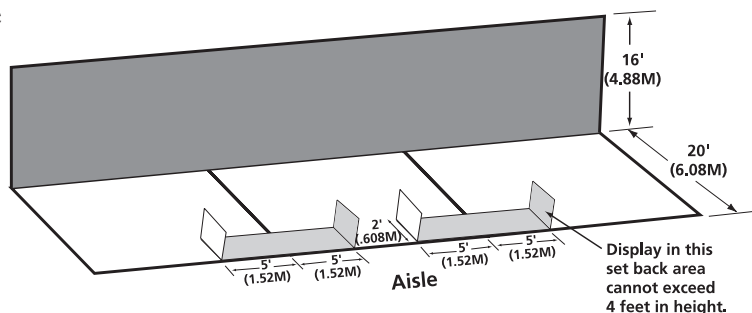

Special note for linear booths at least 20' deep and 600 total square feet or larger:

If booth attaches to other linear booths of equal size or a peninsula booth, then all exhibitors may utilize the entire booth up to a height of 16 feet. There will be no set back for these large linear booths.

MAXIMUM DISPLAY HEIGHT: 16 FEET

Display setback for Irregular booths: contact Event Management.

NOTE: Booths not in compliance with event rules will be required to conform before the opening of the event at the exhibitor’s expense. Please contact Chrissie Hahn at: (703) 264-7200, ext. 267 with any questions about your booth configuration.

PERIMETER WALL BOOTH

(A perimeter wall booth is any linear booth located on the outside wall of the exhibit floor.)

Exhibit fixtures, components, or banners will be permitted to a maximum height of 12 feet. Perimeter booths less than 30 feet long must maintain an area 5 feet from the aisle where display items cannot be higher than 4 feet. The maximum height for display materials in the rear 5 feet of the booth is 12 feet.

Perimeter booths 30 feet long or longer must abide by the above perimeter display rules, but may use the middle 1/3 section of the booth out to the aisle with no 5 foot set-back (neighboring exhibitors must be at least 10 feet away from the middle section that goes 5 feet high.)

MAXIMUM DISPLAY HEIGHT: 12 FEET.

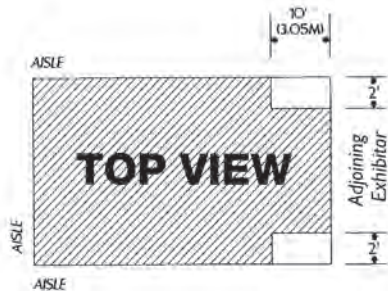
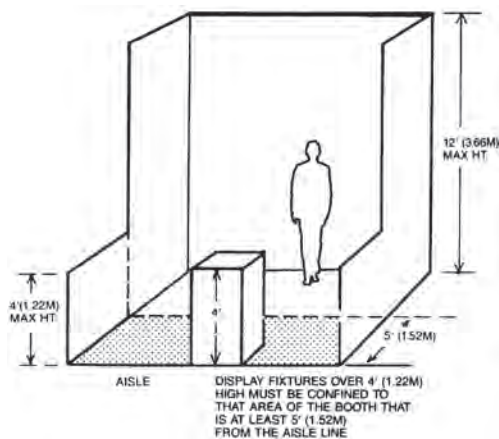

Peninsula Booth

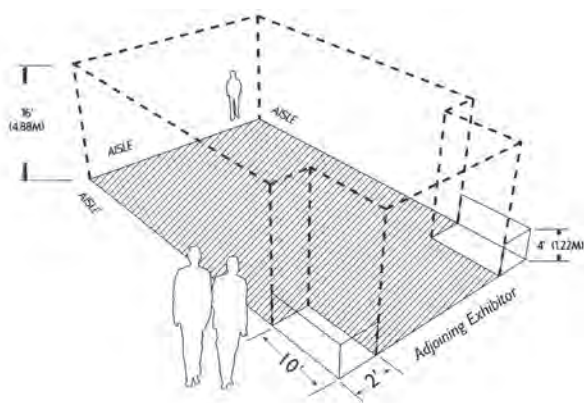

DISPLAY SET-BACK FOR PENINSULA BOOTHS

(A Peninsula Booth is a booth with a minimum size of 20' x 20' with traffic on 3 sides, which shares a backwall with one or more linear booths.)

For peninsula booths of any size attached to linear booths under 599 square feet:

Display materials higher than 4 feet must be set back 2 feet from either aisle with linear neighbors for a length of 10 feet from the neighboring booth. (Example: a 20' x 20' peninsula with linear booths attached may erect a maximum 16 foot wide backwall, and must maintain the 2 foot clearance [on either side] 10 feet into the peninsula booth.) Display items under 4 feet may be placed in this set-back area. Height limitations for display in all other areas of the booth is 16 feet.

MAXIMUM DISPLAY HEIGHT: 16 FEET.

(except in the set-back area noted.)

(For peninsula booths attached to linear booths 600 square feet or more, no set back is required. Exhibitors may utilize the entire booth up to a height of 16 feet.)

MAXIMUM DISPLAY HEIGHT: 16 FEET.

For peninsula booth of any size, attached to another peninsula booth: (See rules for Split Island.)

SPLIT ISLAND BOOTH

(A Split Island Booth is a booth with traffic on 3 sides, which shares a common backwall with another split island booth and is at least 20 feet deep.)

The entire cubic content of this booth may be used up to the maximum allowable height of 16 feet without any backwall line of sight restrictions.

MAXIMUM DISPLAY HEIGHT: 16 FEET.

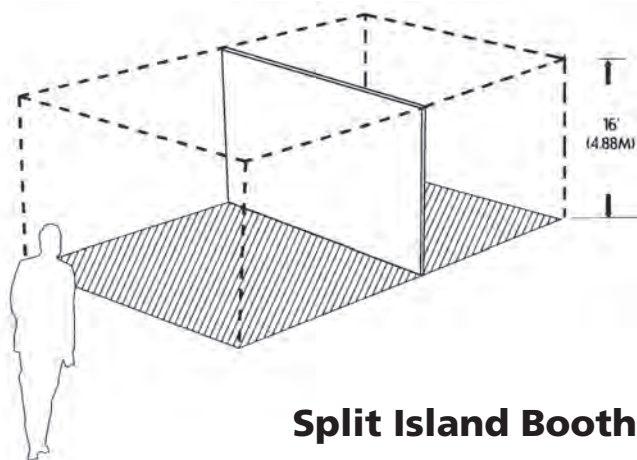

Split Island Booth

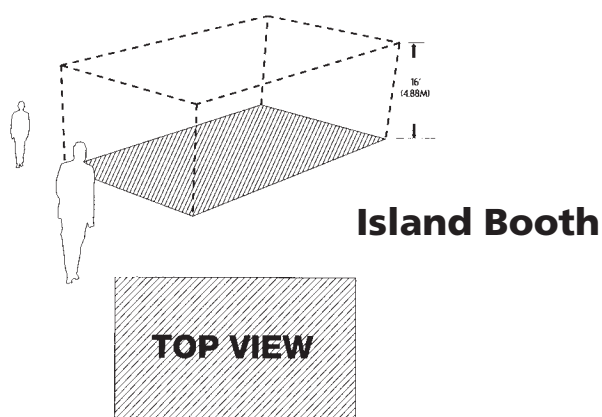

Island Booth

DISPLAY SET-BACK FOR ISLAND BOOTHS

(An Island Booth is a booth with traffic on 4 sides and must be at least 20 feet deep x 20 feet wide.)

Displays for island booths may be constructed to the 16 foot height limit anywhere within the booth. However, no part of the display (such as a door) will be allowed into the aisle.

MAXIMUM DISPLAY HEIGHT: 16 FEET

HANGING SIGN INFORMATION

Make sure your EAC or booth design company gets a copy of this page!

Determining Whether Your Company May Hang a Sign

If your booth is one of the following types, you may hang a sign:

- Island
- Split Island
- Peninsula
- Linear Booth 20' deep or greater
- Perimeter Linear Booth

Please see your booth assignment letter for your type of booth or check the Show Display Rules on the previous pages. **Regular Linear booths may not hang a sign over their booth space.** If you have any questions about whether you may hang a sign or not, contact Chrissie Hahn at: chahn@aptech.org.

Hanging Sign Rules

Please read the Exhibit Display Rules on the previous pages for maximum height of sign and allowed position of sign based on your type of booth. If you have any questions about hanging sign rules, contact Chrissie Hahn at: chahn@aptech.org.

Event Management Approval

Every PRINT 19 exhibitor that hangs a sign, regardless of whether the sign is new or has been used at a prior APTEch event, must send an e-mail to Chrissie Hahn at: chahn@aptech.org outlining the following sign specifications:

- dimensions of sign (height, length, and depth if applicable)
- height at which the top of the sign will be hung
- height of the booth display items in the booth (not machinery)

If diagrams or photos of the sign and booth are available and help explain the above required dimensions, please include in the e-mail. If the diagrams or photos do not show dimensions, please still send them but also include all dimensions in the body of the e-mail. **This information is due by August, 9, 2019.**

Sign Installation

To order labor for assembling and hanging signs, please see the Hanging Sign forms from Freeman under Tab 4.

Even if you complete the order forms for Freeman, you must still send your hanging sign details for Event Management approval to Chrissie Hahn.

**Deadline to send in Hanging Sign plans
for Approval: August 9, 2019**

**For more information, questions or
approval, please mail or email:**

Chrissie Hahn
Association for PRINT Technologies
1899 Preston White Drive
Reston, Virginia 20191 U.S.A.
Telephone: (703) 264-7200 ext. 267
E-mail: chahn@aptech.org • www.PRINTEvent.com

1. ELIGIBLE EXHIBITS. This Exhibition is limited to firms that have contracted and paid for space assignments. No other persons or concerns will be permitted to demonstrate products, solicit contributions, donations, or orders, or distribute advertising materials at the event. The Association for PRINT Technologies (APTech) has sole right to determine the eligibility of any company or product for inclusion in the exposition.

2. PAYMENT: FAILURE TO OCCUPY, CANCELLATION OR REDUCTION OF SPACE. No exhibitor will be permitted to bring any equipment or display any material on the exhibit floor without prior full payment. Space payments are non-refundable. In the event that an exhibitor fails to use all or part of any space contracted for, no part of any payments made with respect to unused space will be returned or applied to amounts due with respect to space actually used or any future contract. The exhibitor shall continue to be obliged to pay for the total amount of space originally contracted for. If not occupied by the time set for completion of installation of displays, such space may be possessed by APTech for such purposes as it may see fit.

3. LIABILITY LIMITATION AND INDEMNIFICATION. Exhibitor waives all claims of every kind against APTech, its directors, officers, stockholders, agents and employees including, without limitation, all claims for damages based on personal property damage, destruction, loss or theft, personal injury or death, cancellation of the event, failure or refusal to provide space for any exhibit, preventing the display, operation, removal or dismantling of any exhibit, and other act or failure to act of APTech. Exhibitor agrees to indemnify and save APTech harmless from all claims, including expenses, damages, costs and attorney's fees, by Exhibitor, Exhibitor's agents, employees, contractors, or by any other person, arising out of any act or omission in any way related to Exhibitor's participation in the Event, whether negligent or not. Such indemnification shall be effective even if such claim results from the negligence of APTech. In the event of cancellation or disruption of the Event for any cause, this Agreement shall terminate and the Exhibitor waives any claim for damages or compensation, except that the Exhibitor shall be entitled to a refund of the amount paid for space for that portion of the event that is either cancelled or disrupted.

4. SUB-LEASING AND IDENTIFYING OTHER PRODUCTS AND SERVICES. Exhibitor shall not let any part of their space, nor exhibit, offer for sale, give as a premium, or provide advertising or literature about articles or services not manufactured in their own name or affiliated company, except where such articles or services are required, as determined by the Event Management, for the proper demonstration or operation of exhibitor's display, in which case identification of such articles or services shall be limited to the regular nameplate, imprint or other identification which in standard practice appears normally on the articles or in connection with the services. No exhibitor shall permit the display, sale or presentation in their booth of products that are not manufactured by the exhibitor or an affiliated company. Rulings of Event Management shall in all instances be final with regard to the use of any exhibit space.

5. NO EXHIBIT OUTSIDE APTech JURISDICTION. No exhibit in the Event will be permitted in a hotel room/suite or outside of the regular jurisdiction of APTech's exposition.

6. HOSPITALITY ACTIVITIES. Exhibitors hosting hospitality functions off the exhibit floor must refrain from holding these activities during official exhibit hours with the exception of luncheon events. Exhibitors may not transport attendees to off-site events during exhibit hours. Only exhibitors in good standing are permitted to host a hospitality function in an official event hotel. All requests for hospitality suite or public function space must be approved by Event Management.

7. PROTECTION OF BUILDING. Nothing should be posted on, or tacked, nailed or screwed, or otherwise attached, to columns, walls, floors, or other parts of the building or furniture. Exhibitor may not apply paint, lacquer, adhesives or other coating, to building columns and floors or to standard booth equipment. Whatever is necessary to properly protect the building, equipment, or furniture will be at the expense of the Exhibitors. Exhibitors are liable for any damage that they cause to the exhibit hall property. Machinery in operation: drip pans and scrap buckets should be provided to keep lubricants, inks, excess materials, etc. from staining floor.

8. UNION LABOR. When required by Union agreement exhibitor shall employ only Union Labor, as made available by official contractors, in the installation and dismantling of his exhibit and its operation.

9. BOOTH REPRESENTATIVES. Exhibitors' booth representatives shall be restricted to employees, dealers and agents of exhibiting companies. Booth representatives shall wear badge identification furnished by Event Management at all times.

10. ADMITTANCE DURING NON-EXHIBIT HOURS. Admittance to the exhibit floor during non-event hours is by special permission only from Event Management. Written special admission passes from Event Management are required to gain access to the exhibit floor during non-exhibit hours.

11. FIRE, SAFETY AND HEALTH. The exhibitor assumes all responsibility for compliance with local, city and state ordinances and regulations covering fire, safety and health in the city in which the exhibition is held. All exhibit equipment and materials will be reasonably located within the booth and protected by safety guards and devices where necessary. Only fireproof materials may be used in displays and the necessary fire precautions will be taken by the exhibitor.

12. SAFETY GUARDS AND PROTECTION. Exhibition guests must be properly protected from injury. Any piece of machinery on display that has movable parts must have adequate safeguards to protect the public from any injuries throughout the exhibit period. Exhibitor agrees to accept full responsibility for compliance with national, state and city regulations in the provision and maintenance of adequate safety devices and conditions for the operation of machinery and equipment.

13. FLOOR LOAD. An exhibitor who plans to show equipment with a weight exceeding the floor load restrictions must position it on suitable wood or steel supports of sufficient size to properly distribute the weight over required area, such supports to be approved by the convention center/facility. In all cases, the exhibitor must submit complete information to the convention hall sufficiently in advance to enable engineering analysis. Exhibitor accepts full and sole responsibility for injury or damage to property or persons resulting from failure, knowingly or otherwise, to distribute the load of their exhibit materials in conformity with maximum floor load specifications.

14. DECORATION. Event Management shall have full discretion and authority in the placing, arrangement, and appearance of all items displayed by exhibitor, and may require the replacing, rearrangement, or redecorating of any item or of any booth and no liability shall attach to Event Management for costs that may be incurred by exhibitor thereby. Exhibitors building special background or side dividers must make certain that the surfaces of such dividers are finished in such a manner as not to be unsightly to exhibitors in adjoining booths. If such surfaces remain unfinished at 6:00 p.m. of the day before the opening of the exposition, Event Management shall authorize the official contractor to effect the necessary finishing, and exhibitor must pay all charges incurred therewith. Exhibitor signs may not extend into or be placed over aisles or other public space. Any use of helium or gas filled balloons must be approved in writing by both building management and Event Management.

15. RULES GOVERNING EXHIBITION. Event Management reserves the right to restrict exhibits which, because of noise, method of operation, or any other reason, become objectionable, or otherwise detract from or are out of keeping with the character of the exhibition as a whole. Exhibitors agree to abide by the "Rules Governing Exhibition" and subsequent amendments as published in the Exhibitor Manual. Exhibitors shall comply with state and local "Health and Safety" standards and applicable rules and regulations of state and local fire authorities. Exhibitors are to surrender spaces occupied by them in the same condition they were at the time when first occupied. Exhibitors are liable for any damage to floors, walls, columns, or other parts of exhibit hall property. The distribution of any material or literature is restricted to Exhibitor's booth area. Popcorn cannot be served or distributed on the exhibit floor. Exhibitors are responsible for all applicable ASCAP/BMI music licensing fees.

16. EXHIBIT BOOTH SET-UP. APTEch Event Management will furnish all in-line or linear booths with a 8' high back drape and 36" high side dividers. Split island booths will be set with 8' high back drape along the back of the booths. Peninsula booths will be set with 8' high back drape along the center 6' of the booth, dropping to 36" high side dividers on each side. All booths, except islands, will be provided with a 7" x 44" identification sign with company name and booth number at no charge.

17. DISPLAY HEIGHTS. See accompanying section (Exhibit Rules for Placement of Display). APTEch rules governing display heights pertain only to the placement of display materials, not machinery. Actual machinery of any height can be placed in any location of the booth but is restricted by building ceiling height and safety rules as stated in Rules 13 and 18.

18. POSITION OF EQUIPMENT WITH RELATION TO AISLE. Machines or equipment operating or demonstrated at any time during exhibit hours shall be so placed so that no portion is closer than 12" to an aisle. Machines must be set within the booth so that any printed matter will fall within the booth space and not the aisle.

19. INSTALLATION AND DISMANTLING. Hours and dates for installation, showing and dismantling shall be those specified by Event Management. It is the duty and responsibility of each exhibitor to have their exhibit completely installed in assigned booth area before the opening of the exposition and to dismantle and remove their exhibit after the close of the exhibition. Exhibitors are not permitted to dismantle their booths prior to the published end of exhibit hours. Exhibitors shall be liable for all storage and handling charges resulting from failure to remove exhibit material from the exposition before conclusion of the dismantling period as specified by Event Management.

20. EXHIBITOR REPRESENTATIVES' RESPONSIBILITY. Exhibitor agrees to indemnify APTEch Event Management against and hold it harmless for any claims arising out of the acts or negligence of exhibitor, their agents, or employees.

21. RESOLUTION OF DISPUTES. In event of a dispute or disagreement between exhibitor and an official contractor, or between exhibitor and a Labor Union or Labor Union representative, or between two or more exhibitors, all interpretation of the rules governing the exposition, actions, or decisions concerning this dispute or disagreement by APTEch Event Management intended to resolve the dispute or disagreement shall be binding on exhibitor.

22. USE OF EXHIBITOR APPOINTED CONTRACTORS. Exhibitors using "exhibitor appointed contractors" (EAC's) for the installation and/or dismantling of their booth must notify Event Management in writing 30 days prior to the first move in day. In addition, the required certifications of insurance from your EAC must be received 30 days prior to move-in. If notification and insurance certificates are not received, exhibitors may use the supervision services of the EAC, but must use the labor of the official general service contractor. For services such as electrical, plumbing, telephone and drayage, no contractor other than the official contractor will be approved.

23. ADDITIONS AND AMENDMENTS TO THE RULES. APTEch, may from time to time issue such additional rules as it deems necessary for the orderly presentation of the Event. Any rule may be amended at any time by APTEch, provided that such amendment shall not substantially diminish the rights or increase the liability of the Exhibitor.

24. AGREEMENT TO RULES. Exhibitor, for them self, their employees and successors agrees to abide by the foregoing rules and by the amendments that may be put into effect by APTEch Event Management.

Accessible Storage – An area provided by show contractors that is accessible during trade show hours for storage of collateral, giveaways, and other items that cannot be stored in the booth but to which an exhibitor needs access.

Advance(d) Order – An order for show services sent to the contractor before move-in.

Air Freight – Materials shipped via airplane.

Air Walls – Movable barriers that partition large areas of exhibit hall or meeting rooms. May be sound-resistant, but not necessarily soundproof.

Aisle Signs – Signs, usually suspended from ceiling, indicating aisle numbers or letters.

ASUV – Automobile or small utility vehicle.

Audio/Visual – Equipment, materials and teaching aids used in sound and visual (also AV).

Backloader – Truck which loads from back opening door.

Backwall – The wall panels that make up the back of an exhibit.

Backwall Booth – see Perimeter Booth.

Baffle – Partition to control light, air, sound, or traffic flow.

Bill of Lading – Document or form listing goods to be shipped.

Blanket Wrap – Non-crated freight shipped via van line covered with protective blankets or padding.

Blister Wrap – Vacuum formed transparent plastic cover.

Bone Yard – Storage area at show site for empty crates and show contractor materials.

Booth Number – Number designated to identify each exhibitor's space.

CAD – Computer-Aided Design.

Canopy – Drapery, awning or other roof-like covering.

Capacity – Maximum number of people allowed in any given area.

Cherry Picker – Equipment capable of lifting a person(s) in an open bucket or cage to a given height (also High Jacker, Scissors Lift) to perform aerial work such as hanging signs from exhibit hall ceiling.

C.O.D. – Cash On Delivery; Collection On Delivery.

Column – A pillar in an exhibition facility that supports the roof or other structures.

Common Carrier – Transportation company that handles crated materials.

Consignee – Person to whom goods are shipped.

Contractor – An individual or company that provides services or materials such as furniture rental, cleaning, utilities, drayage, rigging, etc. to a trade show or its exhibitors; also referred to as Official Contractor or Exhibitor Appointed Contractor.

Corkage – The charge placed on beer, liquor and wine brought into the facility but purchased elsewhere. The charge sometimes includes glassware, ice, and mixers.

Cross Bar – Rod used in draping or as a support brace.

Cut & Lay – Installation of carpet other than normal booth or aisle size.

CWT. – Hundredweight. A weight measurement for exhibit freight. Usually 100 pounds.

Decorating – Dressing up exhibition with carpet, draping, furniture, plants, etc.

Decorator – General Contractor or Service Contractor.

Direct Billing – Accounts receivable mailed to individuals or firms with established credit.

Dismantle – Take-down and removal of exhibit.

Display Builder – Company that fabricates trade show exhibits.

Dock – A place where freight is loaded onto and taken from vehicles (also see Loading Dock).

Dolly – Low, flat, usually two feet square platform on four wheels used for carrying heavy loads.

- Drayage** – The unloading of your shipment, transporting it to your booth, storing and returning your empty crates and cartons and reloading your shipment at the close of the event.
- Duplex Outlet** – Double electrical outlet.
- EAC or Exhibitor Appointed Contractor** – Any company other than the designated official contractor the exhibitor hires to do work in the exhibitor’s booth.
- Electrical Contractor** – Company contracted by Event Management to provide electrical services to the exhibitor.
- Electrician** – Handles installation of all electrical equipment.
- Event Manager** – Person responsible for all aspects of exhibition.
- Event Office** – Management office on-site at exhibition.
- Exclusive Contractor** – Contractor appointed by event or building management as the sole agent to provide services (also Official).
- Exhibit Booth** – Individual display area constructed to exhibit products or convey a message.
- Exhibit Directory** – Program book for attendees listing exhibitors and exhibit booth location (also Event Guide).
- Exhibit Manager** – Person in charge of individual exhibit booth.
- Exhibitor Service Desk** – A location in the exhibit hall at which exhibitors can order services from official contractors.
- FHC** – Floor plan notation for Fire Hose Cabinet – usually attached to a column. Display items must be kept clear of this cabinet.
- Fire Exit** – Door designated by local authorities for egress that must be kept clear of obstructions.
- Fire Retardant** – Term used to describe a finish (usually liquid) that coats materials with a fire resistant cover.
- Flame Proof** – Term used to describe material that is, or had been, treated to be fire retardant.
- Floater** – Worker(s) used by foreman to help assigned labor for short periods of time.
- Floor Manager** – Person retained by Event Management to supervise exhibit area and assist exhibitors.
- Floor Marking** – Process of marking booth spaces on the exhibit floor prior to booth set up.
- Floor Order** – Foods and/or services ordered on-site.
- Floor Plan** – A map showing the layout of exhibit spaces, booth numbers, and booth sizes.
- Floor Port** – Utility box located in the floor to house electrical, telephone, or plumbing connections for exhibitors.
- Foam Core** – Lightweight material with a Styrofoam center used for signs, decorating and exhibit construction.
- Foreman** – A lead worker who manages the work of union workers and the overall project. A foreman can work for the Official Contractor or for an Exhibitor Appointed Contractor.
- Fork Lift** – Vehicle with power-operated prolonged platform for lifting and carrying loads.
- Four-Hour Call** – Minimum work period for which union labor must be paid.
- Freight** – Exhibit properties, products and other materials shipped for an exhibit.
- Freight Forwarder** – Shipping company.
- Full Booth Coverage** – Carpet covering entire area of booth.
- Garment Rack** – Frame that holds apparel.
- Guarantee** – The number or servings to be paid for, whether or not they are actually consumed; usually required forty-eight hours in advance.
- Hand Truck** – Small hand-propelled implement with two wheels and two handles for transporting small loads.
- Hardwall Booth** – A trade show exhibit with walls and components constructed of a solid material rather than fabric or other flexible materials.
- Header** – A sign or other structure prominently located at the top of an exhibit often used to display the exhibit company’s logo or tagline.
- Hospitality Suite** – Room or suite used to entertain guests.
- I & D** – Install and Dismantle.
- I.D. Sign** – Booth identification sign.
- Illuminations** – Lighting available in hall, built into exhibit or available on a rental basis.
- Infringement** – Unauthorized use of floor space outside contracted booth area by an exhibitor.
- Inherent Flame Proof** – Material that is permanently flame resistant without chemical treatment.

- In-Line Booth** – Booth that is positioned in a continuous line with other booths along an aisle in the exhibit hall; also referred to as a linear booth.
- Installation** – Setting up exhibit booth and materials according to instructions and drawings.
- Island Booth** – An exhibit space with aisles on all four sides.
- Job Foreman** – One who is in charge of specific projects.
- Kiosk** – Free standing pavilion or light structure.
- Labor** – Refers to contracted workers who perform services.
- Labor Call** – Method of securing union employees.
- Labor Desk** – On-site area from which service personnel are dispatched.
- Light Box** – Enclosure with lighting and translucent face of plastic or glass.
- Line of Sight** – View down an aisle of an in-line or linear display that restricts exhibitors from positioning any booth components higher than 4' in the front half of their booth space so as to not block the attendee's view of neighboring exhibits.
- Linear Booth** – Booth that is positioned in a continuous line with other booths along an aisle in the exhibit hall; also referred to as an in-line booth.
- Loading Dock** – Area at the trade show where freight is delivered, received, re-loaded, and shipped.
- Lobby** – Public area that serves as an entrance or waiting area.
- Lock-Up** – Storage area that can be locked up.
- Marshalling Yard** – Check-in area for trucks delivering exhibit material.
- Modular Exhibit** – Exhibit constructed with interchangeable components for use in various booth configurations and sizes.
- Move-In** – Date set for delivery and installation of exhibitors' booths. Also the process of setting up exhibits.
- Move-Out** – Date set for dismantling exhibitors' booths and shipping out the freight. Also, the process of dismantling exhibits.
- Mylar** – Trade name for plastic material.
- Net Square Feet or Net Square Footage** – The amount of space occupied by exhibits in a facility, not including aisles, columns, registration area, etc.
- News Room** – Space reserved for media representatives. Exhibitors may deliver their press releases to this room for media distribution
- No Freight Aisle** – Aisle that must be kept clear at all times during set-up and dismantle. Used to deliver freight, remove empty boxes and trash, and in case of emergency.
- Official Contractor** – General contractor or decorator appointed by Event Management to provide services to the exhibitors.
- On-Site Order** – Service order placed at show site.
- On-Site Registration** – Process of signing up for an event on the day of, or at the site of the event.
- O.T. Labor** – Work performed on overtime.
- Package Plan** – Management providing furniture and/or services to exhibitors for a single fee.
- Padded Van Shipment** – Shipment of crated or uncrated goods such as product or display material (also Van Shipment, Air-Ride).
- Pallet** – Wooden platform used to carry goods (also Skid).
- Pegboard Panel** – Framed panel of perforated hardboard.
- Peninsula Booth** – Exhibit Space with aisles on three sides; fourth side is adjacent to another booth.
- Perimeter Booth** – Exhibit space located on the outside wall or the outermost perimeter of the entire exhibit floor.
- Pipe and Drape** – Metal tubing with drapes that separates exhibit booths.
- Popup Display** – A lightweight trade show display with an expanding framework that supports fabric or graphic panels; accessories include lights, shelves, monitor cut-outs, and more.
- POV** – Privately-Owned Vehicle. A vehicle the exhibitor drives to the event to deliver display items or booth materials.

- Pre-Registered** – Reservation that has been made in advance with necessary paperwork.
- Private Security** – Security personnel hired from a privately operated company (also Booth Security).
- Pro-Number** – Number assigned by the freight forwarders to a single shipment, used in all cases where reference is made to the shipment.
- Quad Box** – Four electrical outlets in one box.
- Rail** – Low pipe and drape divider between exhibit booths (also Side Rail).
- Rear-Lit** – Method of lighting transparency from behind.
- Registration** – Process by which an individual indicates their intent to attend an event or conference.
- Rental Booth** – Complete booth package offered to exhibitors on a rental basis.
- Rigger** – A worker skilled at handling and/or assembling machinery during setup and dismantle of an event.
- Riser** – A platform for people or product.
- Scissors Lift** – A motorized platform used to lift people and exhibit materials to a given height to install hanging signs, support cables, truss systems, or electrical equipment in the exhibit hall.
- Security Cages** – Cages rented by exhibitors to lock up materials.
- Service Charge** – Charge for the services of waiters/waitresses, housemen, technicians and other food function personnel.
- Shop** – Service contractor’s main office and warehouse.
- Showcard** – Material used for signs.
- Showcase** – Glass enclosed case for articles on display.
- Shrink-Wrap** – Process of wrapping loose items on pallet with transparent plastic wrapping.
- Side Rail** – Low divider wall in exhibit area.
- Skirting** – Decorative coverings around tables and risers.
- Space Assignment** – Booth space assigned to exhibiting companies.
- Space Rate** – Cost per square foot for exhibit area.
- Special Handling** – A surcharge applied to exhibit freight that is loaded in a carrier in such a way that additional labor hours or special equipment are required to load or unload; includes stacked materials, ground handling, hoisting, designated loading sequence, and side door loading and unloading.
- Spotting** – Placing freight in or next to your booth. Spotting might need to be repeated if your freight needs to be unwrapped or uncrated or if it was not initially correctly placed.
- Staging Area** – Area adjacent to main event area for setup, dismantling and temporary storage.
- Stanchions** – Posts which define traffic areas. Ropes or chains may be attached.
- S.T. Labor** – Work performed on straight time.
- Strike** – Dismantle exhibits.
- Target Date** – Move-in date assigned to exhibitors over 300 square feet by the general contractor and Event Management.
- Teamster** – Union worker that handles all material moving in and out of the hall except machinery. Exhibitors are permitted to hand carry small packages into the hall.
- Time & Materials** – Method of charging for several services on a cost-plus basis (also T&M).
- Traffic Flow** – Movement of people through an area.
- Union** – An organization or workers formed for mutual protection and for the purpose of dealing collectively with their employer in wages, hours, working conditions and other matters pertaining to the employment.
- Union Steward** – On-site union official who supervises worker and show activities.
- Velcro** – Material used for fastening.
- Waste Removal** – Removal of trash from the building.

Secure Your On-Site Exhibitor Meeting Room Today!

Exhibitor meeting rooms on the event floor come furnished and provide you the convenience you can't find using an off-site rented room.

You can access your meeting room(s) for each day of PRINT 19, during approved hours only (see rules & regulations).

For more information, contact the APtech Sales Team at: (703) 264-7200 or chahn@aptech.org.

TOTAL PRICE FOR 3 EVENT DAYS

Furnished Meeting Rooms

12' x 12' Meeting Room(s)	\$4,000 (Seats 6)
12' x 24' Meeting Room(s)	\$6,500 (Seats 12)
24' x 24' Meeting Room(s)	\$9,000 (Seats 18)

Furnished Room Includes:

- Temporary hardwall construction with a door for privacy.
- Carpet
- Small Sign with company name
- Chairs - 6, 12 or 18 depending on room size
- Conference Table(s) (large enough to accommodate maximum seating possible in room.)
- Wastebasket
- Ceiling or lights not provided
- Two (2) standard electrical outlets (120v/15amp)

Note: No substitutions are available for above items.

RULES & REGULATIONS

- Any company applying for an Exhibitor Meeting Room must have an exhibit booth on the exhibit floor.
- Cancellation of your exhibit booth will automatically cancel the reservation of the Exhibitor Meeting Room(s) and cancellation fees will apply. (See cancellation policy)
- Exhibitor Meeting Rooms may be accessed 1 hour before the event opens except on the first day of the event; during exhibit hours; and 1 hour after the close of the event except on the last day of the event.
- Functions in the Exhibitor Meeting Rooms, such as receptions and product demonstrations will not be allowed.
- Catering for meetings, however, is permitted and exhibitors must order all food and beverage items from the official food service provider at McCormick Place, SAVOR...Chicago. Please reference your meeting room number.
- Additional services such as audio visual equipment, electricity, internet, telephone, and special furniture may be ordered at the exhibiting company's expense.
- Exhibitor may not sublet the whole or any part of the space allotted nor use the room for storage.

Company Name: _____ Booth Number: _____

Company Name as it should appear on Meeting Room Sign: _____

Meeting Room Contact from Your Company: _____

Title: _____

Address: _____

City: _____ State: _____ Zip: _____ Country: _____

Phone: _____ Fax: _____

E-Mail: _____

Please list competitors or companies you wish to be separated from if possible: _____

Signature: _____ Date: _____

MEETING SPACE REQUIREMENTS

	<u>FURNISHED</u>	<u>QUANTITY</u>	<u>MEETING ROOM #</u>
12' x 12' Meeting Room(s)	\$4,000 ea.	_____	_____
12' x 24' Meeting Room(s)	\$6,500 ea.	_____	_____
24' x 24' Meeting Room(s)	\$9,000 ea.	_____	_____

Total Price: _____

Full payment due with application

EVENT HOURS

Thursday, October 3, 10 am – 5:00 pm; Friday – October 4, 9:00 am – 5:00 pm;

Saturday, October 5, 9:00 am – 3:00 pm

Exhibitor Meeting Rooms may be accessed 1 hour before the exhibit floor opens except on the first day of the event; during exhibit hours; and 1 hour after the close of the exhibit floor except on the last day of the event.

PAYMENT OPTIONS

Mail Application and Check to:

Association for PRINT Technologies
Attn: Exhibit Sales - PRINT 19
PO Box 79842
Baltimore, MD 21279-0842

Cancellation Policy: Exhibitor may cancel their meeting room space only by giving written notice to APTEch. Meeting room cancellations received:

- a) From date of signature through 8/23/19 exhibitor agrees to pay as liquidated damages 25% of meeting room cost.
- b) After 8/23/19 exhibitor agrees to pay as liquidated damages 100% of meeting room cost.

OR

Fax Application and Credit Card Information

to: 703-620-9187 or Email to: chahn@aptech.org

I authorize Association for PRINT Technologies (APTEch) to charge my:

MC Visa AMEX Discover Diners Club

Account Number _____

Expiration Date _____ Security Code _____

the amount of \$ _____ for a deposit on meeting room space.

Name on Card _____
(print)

Authorized Signature _____